



MCO-MAK Outdoor Cabinet

Customized Battery Cabinet Solutions

Outdoor, designed to protect your 7/24 continuous working electronic system devices against external environmental effects, Vandalism, EMC and high external temperature.

This perfect structure provides high strength and protection in every place where it's necessary.



www.mak-powersis.de



Where to Use

- ✓ Telecommunication
- ✓ IT
- ✓ Energy
- ✓ Defense

Structure :

- ⇒ Extruded aluminium profile construction
- ⇒ Double skin aluminium doors and panels provide natural ventilation system and isolation
- ⇒ IP55 Protected
- ⇒ Sandwich Panel Technology : Double skin construction allows maximum heat dissipation by low influence of sun irradiation and offers maximum sealing effect
- ⇒ Anti-Condensation Paint: Protect surfaces against moisture and condensation heat insulation
- ⇒ Anti-Graffiti Paint: Special sun reflecting ensures up to 6 °C temperature isolation
- ⇒ Ventilated roof top to ensure max ventilation by creating a stack effect
- ⇒ Designed for anti-vandalism
- ⇒ Maximum protection against environmental impacts; vandalism, EMC and extreme thermal effects
- ⇒ Hidden hinges secure external access
- ⇒ Stainless steel (3 point) locking system
- ⇒ 19" rack mountable design
- ⇒ Separated units (optional)
- ⇒ Laptop shelves on doors (optional)
- ⇒ Customer-specific solutions for installation and expansion

Materials :

- Doors and outer panels : 3 mm aluminium
- Inner panels : 1.5 mm aluminium
- Base : 2 mm stainless steel
- Corner profiles: 3 mm aluminium
- Profiles: 2mm aluminium (Special design)
- Top: 3 mm aluminium
- 19" Device Carriers: 2 mm stainless steel

Aluminium profile construction

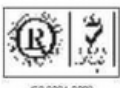
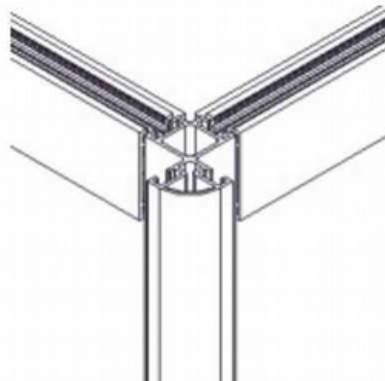

ISO 9001-2008



IEC 60297-3-100
EN 61587-1-2012



ENVIRONMENT FRIENDLY
RECYCLABLE MATERIAL



Technical Details



- * Adjustable Layers
- * Auto Control AC Fans



Optional Air Conditioner
For IP55 and IP65